



AGA ERA
Model No's: 110-3i
Installation Guide

WARNING!

Please read the Warning, Cautionary notes at the start of this section. If the information contained within these instructions is not followed, property damage or personal injury may occur.

DO NOT store or use gasoline or other flammable vapors and liquids in the vicinity of this or any other appliance.

Installation and service must be performed by a qualified installer or service agency.

WARNING! This appliance must be installed with an appropriate device that will allow permanent disconnection of the Live and Neutral conductors. During Installation or disconnection prior to any electrical work, the appliance must be permanently disconnected from the Supply (Live) and Neutral Conductors.

CAUTION: THIS UNIT IS HEAVY, PROPER EQUIPMENT AND ADEQUATE MANPOWER MUST BE USED IN MOVING THE RANGE TO AVOID DAMAGE TO THE UNIT OR THE FLOOR.

REMEMBER, when replacing a part on this appliance, use only spare parts that you can be assured conform to the safety and performance specification that we require.

DO NOT use reconditioned or copy parts that have not been clearly authorised by AGA.

**PLEASE READ THESE INSTRUCTIONS BEFORE USING THIS APPLIANCE
AND KEEP IN A SAFE PLACE FOR FUTURE REFERENCE.**

Contents

1. Health and Safety	1
2. Installation requirements	3
Delivery requirements	3
Appliance dimensions - AGA ERA 110-3i	4
Clearances	5
Kitchen cabinet handle clearance	6
Power supply - AGA ERA	7
Mains cable routing - AGA ERA	8
Wiring Diagram	10

1. Health and Safety

Consumer Protection

As a responsible manufacturer, we take care to make sure that our products are designed and constructed to meet the required safety standards when properly installed and used.

- ⚠ Children less than 8 years of age shall be kept away unless continuously supervised. Cleaning and user maintenance MUST not be made by children without supervision.**
- ⚠ CHILDREN SHOULD BE KEPT AWAY FROM THE APPLIANCE AS SOME SURFACES CAN BECOME HOT TO THE TOUCH.**
- ⚠ WARNING: ACCESSIBLE PARTS MAY BECOME HOT DURING USE. TO AVOID BURNS AND SCALDS CHILDREN SHOULD BE KEPT AWAY.**
- ⚠ WARNING: During use the appliance becomes hot. Care should be taken to avoid touching heating elements inside the ovens.**
- ⚠ WARNING : Any spillages should be removed from the hotplate lids before they are opened.**
- ⚠ WARNING : This appliance is not intended to be operated by means of an external timer not approved by AGA or a separate remote-control system.**
- ⚠ CAUTION: The cooking process has to be supervised. A short term cooking process has to be supervised continuously.**
- ⚠ WARNING: Danger of fire: Do not store items on the cooking surfaces.**
- ⚠ WARNING: Unattended cooking on a hob with fat or oil can be dangerous and may result in fire. NEVER try to extinguish a fire with water, but switch off the appliance and then cover flame e.g. with a lid or fire blanket.**
- ⚠ IMPORTANT: Oil is a fire risk, NEVER leave pans containing oil or fat unattended during the heating or cooking period.**
- ⚠ Never fill the pan more than one-third fill of fat or oil.**
- ⚠ Installation and maintenance must be performed by a qualified installer or service agency.**
- ⚠ WARNING! This appliance must be installed with an appropriate device that will allow permanent disconnection of the Live and Neutral conductors. During Installation or disconnection prior to any electrical work, the appliance must be permanently disconnected from the Supply (Live) and Neutral Conductors.**
- ⚠ If a supply cord is damaged it must be replaced by the manufacturer, its service agent or similarly qualified persons in order to avoid a hazard.**

This appliance operates on single phase. To adjust to 2 or 3 phase installation, an optional adapter kit must be obtained (Part No. AE4M280354).

- ⚠ DO NOT use a steam cleaner on your cooker.**
- ⚠ To avoid overheating, DO NOT install the cooker behind a decorative door.**
- ⚠ For correct installation of the oven shelves, refer to the user instructions.**
- ⚠ DO NOT use abrasive pads, caustic cleaners, oven cleaners or metal scrapers to clean the surfaces of the enamel.**
- ⚠ IMPORTANT: AGA recommend Vitreous Enamel Association approved cleaners for cleaning the vitreous enamelled surfaces of this product.**
- ⚠ DO NOT put oven doors in a dishwasher.**
- ⚠ Children should be supervised to ensure that they do not play with the appliance.**

Cooker Base or Hearth

It is essential that the base or hearth on which the cooker and should be level and capable of supporting the total weight of the unit.

The front plinth cover is removable and must not be obstructed by flooring or tiles. If necessary the cooker must be raised by the thickness of the tiles to ensure the plinth can be removed.

The appliance can be used by children aged from 8 years and above and persons with reduced physical, sensory or mental capabilities or lack of experience and knowledge if they have been given supervision or instruction concerning use of the appliance in a safe way and understand the hazards involved.

The appliance may contain some of the materials that are indicated below. It is the Users/Installers responsibility to ensure that the necessary personal protective clothing is worn when handling where applicable, the pertinent parts that contain any of the listed materials that could be interpreted as being injurious to health and safety, see below for information.

Glues and Sealants

Exercise caution - if they are still in liquid form use face mask and disposable gloves.

Glass Yarn, Mineral Wool, Insulation Pads, Ceramic Fibre

May be harmful if inhaled. May be irritating to skin, eyes, nose and throat. When handling avoid contact with skin or eyes. Use disposable gloves, face-masks and eye protection. After handling wash hands and other exposed parts. When disposing of the product, reduce dust with water spray, ensure that parts are securely wrapped.

General

- In the event of a fire, cover the pan with a lid and switch OFF the electricity.
- Smother the flames on the hob rather than attempting to remove the pan to the outside.
- Burns and injuries are caused almost invariably by picking up the burning pan to carry outside.

Deep Fat Frying

- Use a deep pan, large enough to completely cover the appropriate heating area.

2. Installation requirements

THIS APPLIANCE MUST ONLY BE INSTALLED BY COMPETENT ENGINEERS WHO HAVE BEEN SPECIFICALLY FACTORY TRAINED ON THE PRODUCT AND WHO HAVE THE APPROPRIATE EQUIPMENT.

With specific exceptions, the installing of any type of AGA cooker is subject to the respective directions contained in the current issue of the Building Regulations. In addition, planning permission may need to be obtained, which should be applied for separately.

The installation of the appliance must be in accordance with the relevant requirements of the IET Wiring Regulations and Building Regulations. It should be in accordance also with any requirements of the local authority.

In your own interest, and that of safety to comply with the law all appliances should be installed by an authorised AGA engineer or distributor, in accordance with the relevant regulations.

Delivery requirements

- The AGA ERA arrives on 1 pallet

There must be access to the kitchen to manipulate a foot print of 1120mm x 735mm. A wooden template (skate with castor wheels) of dimensions 1120mm x 735mm could be used to check if the AGA ERA fully built appliance is able to fit through the property grounds and doors into its installation position in the kitchen. It must also be considered that the height of the appliance is 960mm off pallet and 1100mm on the pallet, so high level obstacles/restrictions must not be overlooked.

If this skate/template can be manipulated through the property grounds and doors into position, then the AGA ERA can be installed as intended with no re-work.

Appliance dimensions - AGA ERA 110-3i

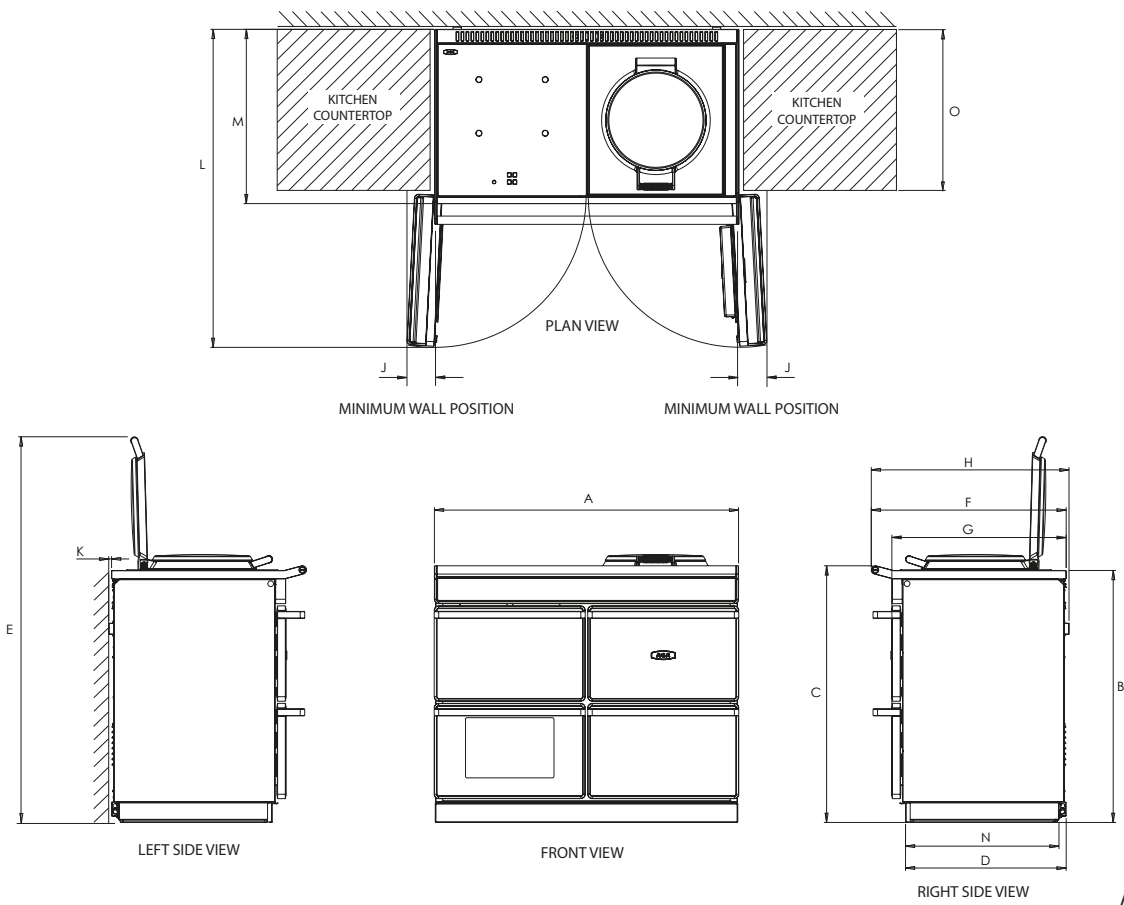

Fig. 2.1

AGDN 100515

	A	B	C	D	E	F	G	H	J	K	L	M	N	O
mm	1100	911	928	581	1395	705	630	715	130	10	1150	630	555	600

Cooker Dimensions

When surveying for a cooker installation the actual clearance required for the 'body' of the appliance should be increased by 10mm beyond the figures quoted above. This allows safe margin to take into account the natural dimensional variations found in major castings. In particular the width across the appliance recess could be critical.

APPLIANCE WEIGHT

Model: AGA ERA - 320kg

Clearances

The complete cooker is floor-mounted and the space in which the appliance is to be fitted must have the following minimum dimensions:-

A minimum clearance of 60mm is required above the raised insulating cover handle.

Side Clearances: A 3mm gap is required each side between the cooker top plate and adjoining work surfaces that may be fitted, this is to allow for the safe removal of the top plate should this be required at a later date.

Where cookers are fitted against side walls a 130mm clearance is required (plus extra space for any cabinet handles) on the right and left hand side for oven doors access (**Fig. 2.2**).

If the AGA is to be installed in a brick recess, then the minimum clearance should be increased by at least 10mm, to allow for the walls not being square.

In addition, a minimum clearance of 1000mm must be available at the front of the cooker to enable the cooker to be serviced.

Cooker Base or Hearth

It is essential that the base or hearth on which the cooker stands should be level and be capable of supporting the total weight of the appliance. The base of the built-in AGA plinth must be level and sit above finished floor height for service access.

The front plinth cover is removable and must not be obstructed by flooring or tiles. If necessary the cooker must be raised by the thickness of the tiles to ensure the plinth can be removed. Shims are provided to eliminate rocking.

Tiling

When the cooker is to stand in a recess or against a wall which is to be tiled, in no circumstances should the tiles overlap the cooker top plate, access to remove the hot plate must be allowed for servicing at a later date.

A gap of at least 10mm must be observed between the rear of the top plate, and the wall behind the appliance.

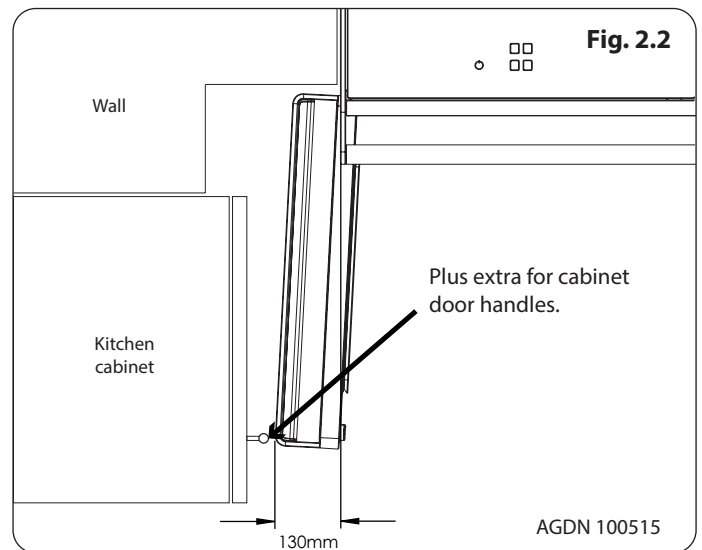

Kitchen cabinet handle clearance

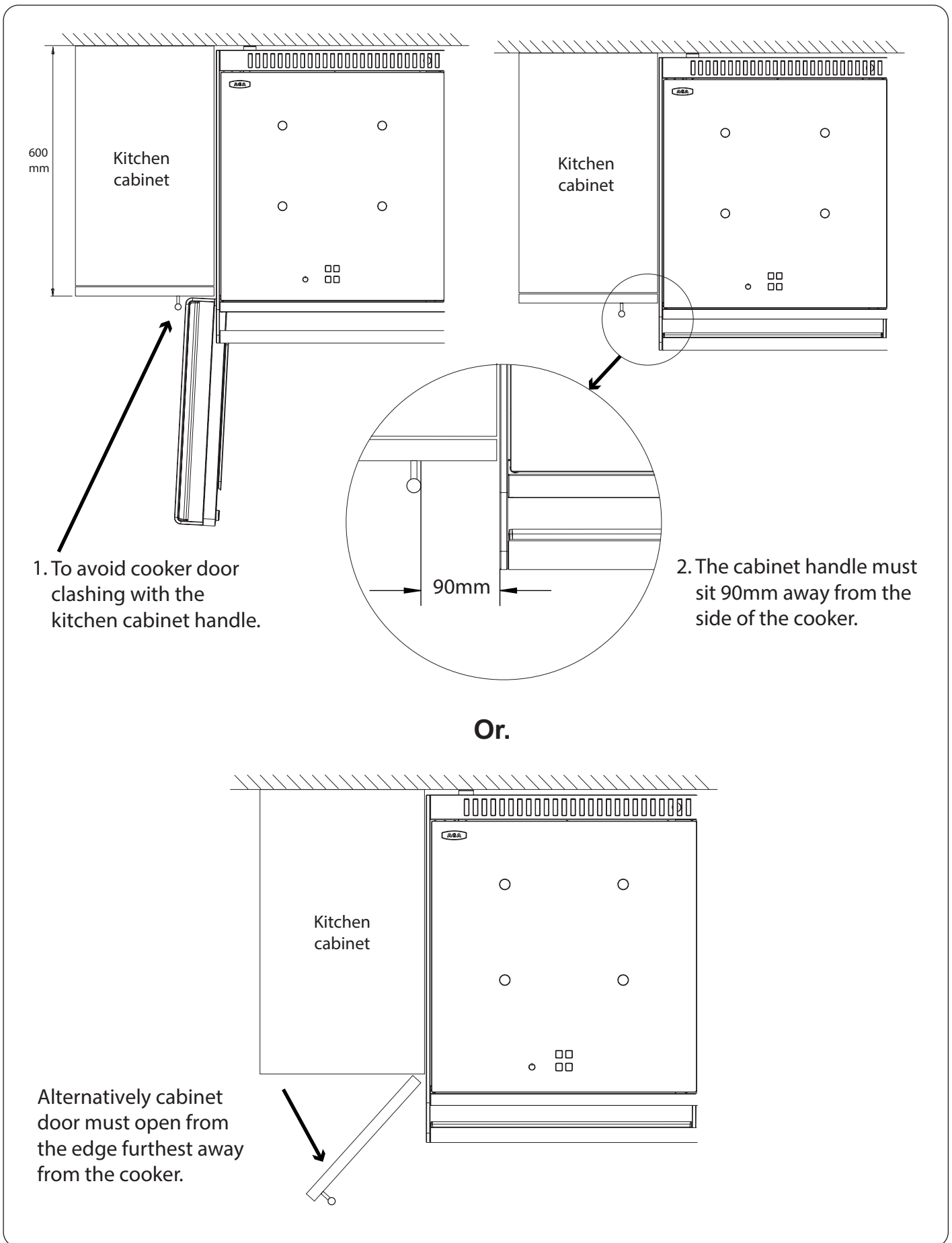

Power supply - AGA ERA

⚠ WARNING: THIS APPLIANCE MUST BE EARTHED.

THIS APPLIANCE IS DESIGNED FOR THE VOLTAGE STATED ON THE RATING PLATE, WHICH IS SITUATED BEHIND THE PLINTH COVER.

IF THE SUPPLY CORD IS DAMAGED, IT MUST BE REPLACED BY THE MANUFACTURER, ITS SERVICE AGENT OR SIMILARLY QUALIFIED PERSON TO AVOID A HAZARD.

A 1PH 32 amp 230V or 3PH 400V minimum 16A per phase ~ 50 Hz fused electrical supply is required adjacent to the appliance. For single phase connection a minimum cable size of 6mm² is to be used between cooker cable connection point and the home's main distribution board. External wiring to the unit must be installed using the mains cable provided, in accordance with the current wiring regulations and any local regulations which apply. If cable is shortened, new ferrules must be fitted to the stripped conductors.

The method of connection to the mains electricity supply must facilitate complete electrical isolation of the appliance, by a multi-pole switch, having a contact separation of at least 3mm on all poles.

The isolator should not be positioned immediately above the cooker, but must be fitted within 2 metres of the appliance.

The isolator maybe separate from the connection point.

The mains connection point must be accessible within the areas shown in **Fig. 2.3** for cable routing options.

For 2 or 3 phase installations an optional adaptor kit must be obtained (Part No. AE4M280354).

Induction hob

An additional, separate single phase power supply is required.

230v ~ 50Hz, 13 amp power supply such as a fused spur.

Mains cable routing - AGA ERA

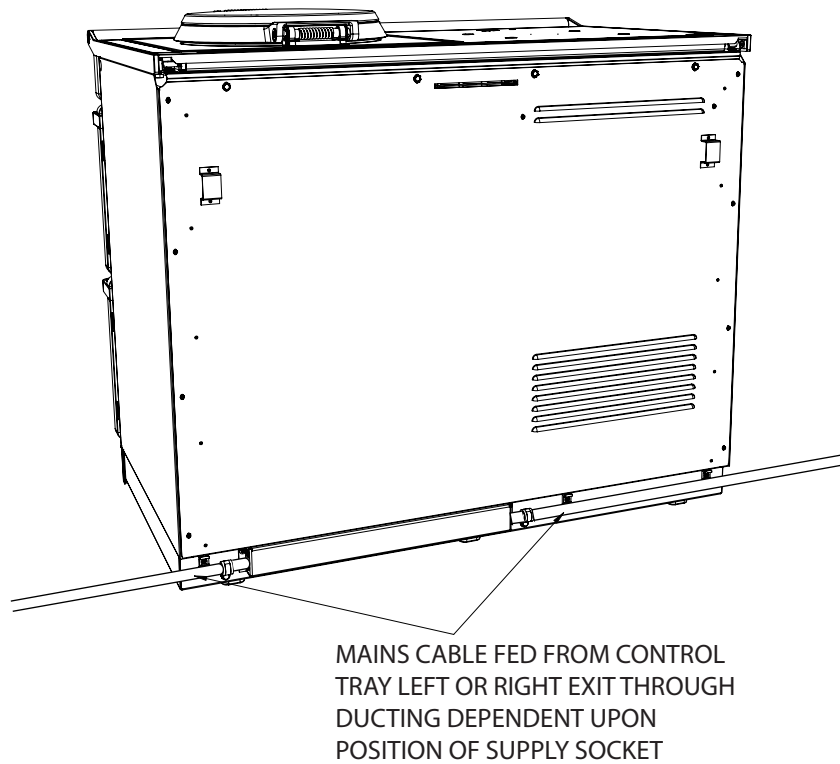
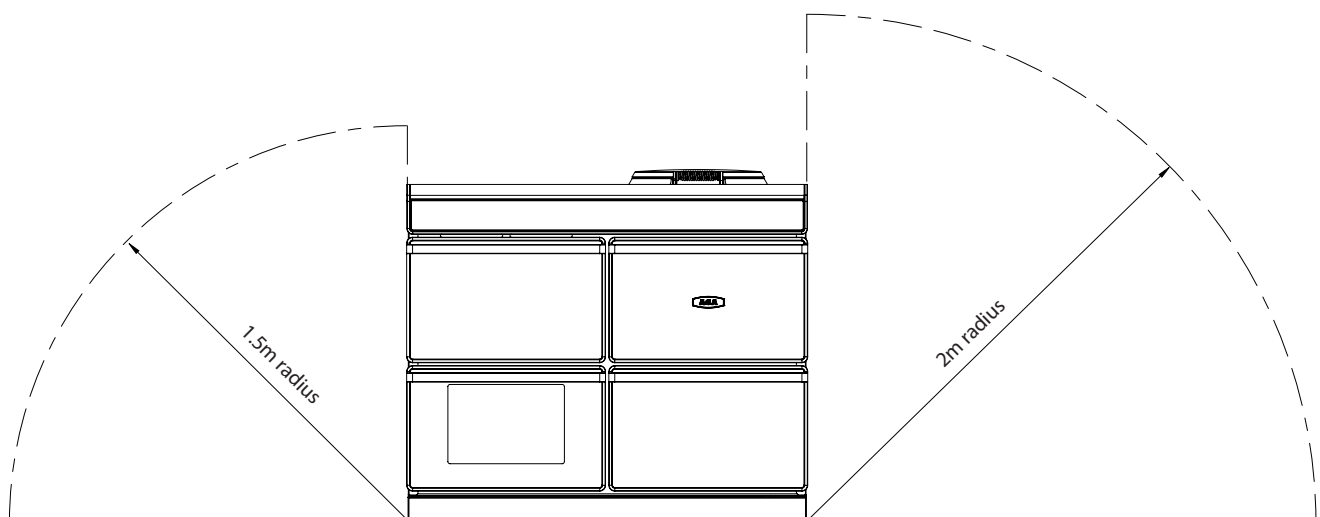

Fig. 2.3

AGDN 100516



THE MAINS SUPPLY CONNECT POINT MUST BE WITHIN THE ZONES SHOWN

Fig. 2.4

AGDN 100517

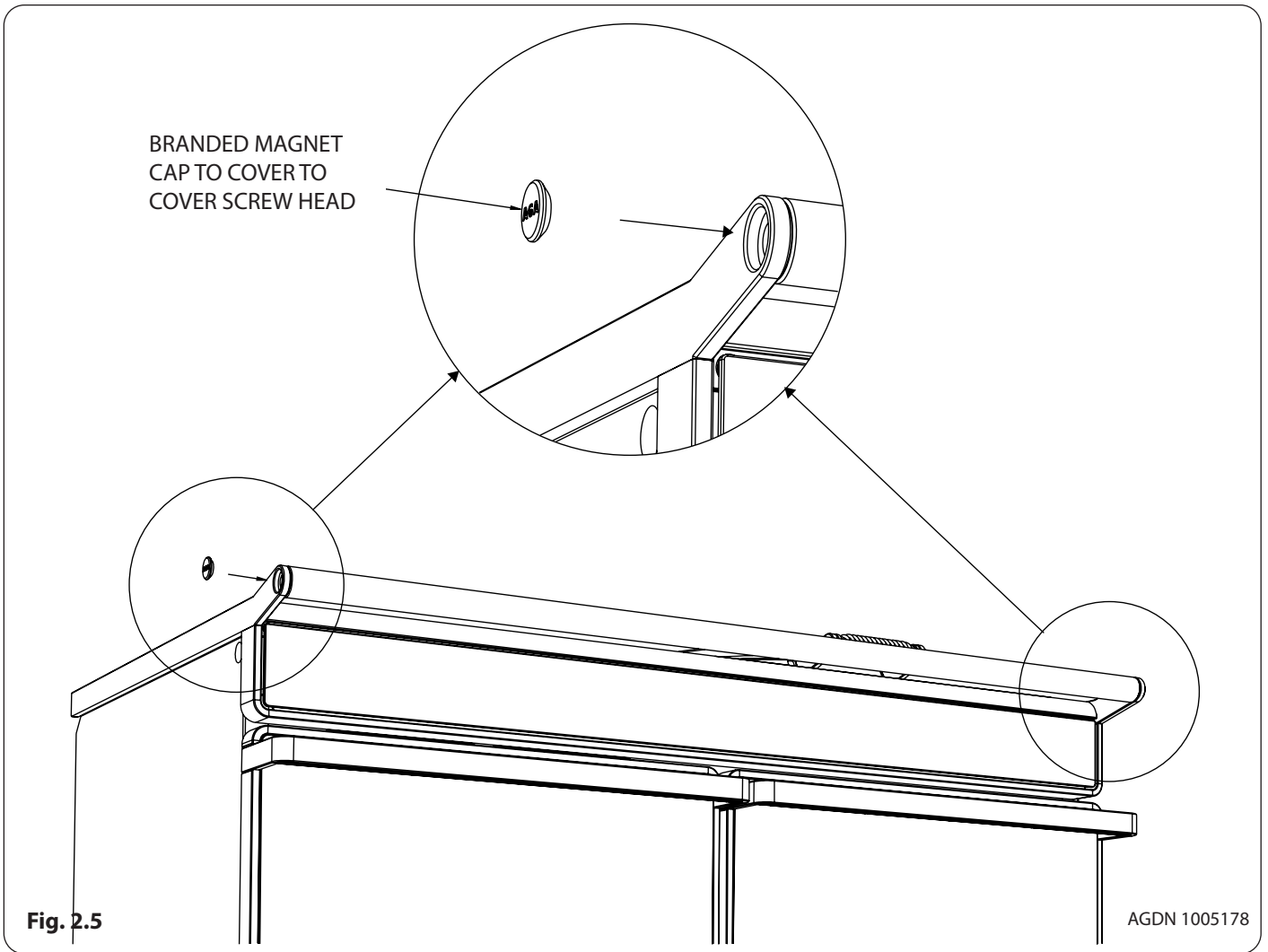

1. The handrail magnet caps attach to the screw that connects the handrail to the top plate.

Wiring Diagram

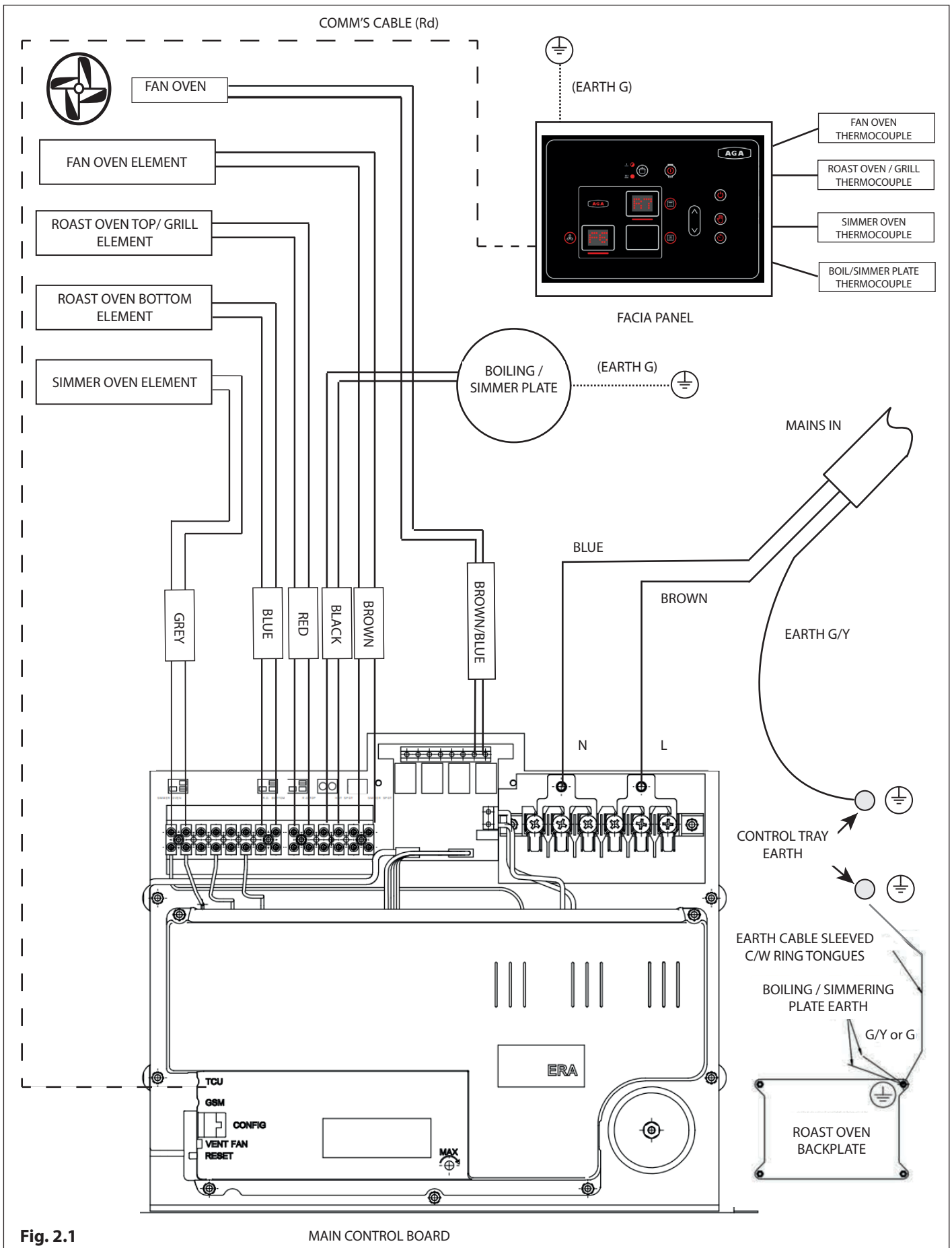

Fig. 2.1

MAIN CONTROL BOARD

**For further advice or information contact
your local AGA Specialist.**

With AGA Rangemaster's policy of continuous product improvement, the Company reserves the right to change specifications and make modifications to the appliances described and illustrated at any time.



Manufactured By
AGA Rangemaster
Station Road
Ketley Telford
Shropshire TF1 5AQ
England

www.agaliving.com
www.agacookshop.co.uk

