



Gas Fired Cookers

Operating Instructions for AGA Gas Fired Cooker Models GC, GCB, (2 Oven) GE, GEB, (4 Oven)

FOR USE IN AUSTRALIA

PLEASE READ THESE INSTRUCTIONS BEFORE USING YOUR AGA

Consumer Protection

As responsible manufacturers we take care to make sure that our products are designed and constructed to meet the required safety standards when properly installed and used.

IMPORTANT NOTICE: PLEASE READ THE ACCOMPANYING WARRANTY. Any alteration that is not approved by AGA, could invalidate the approval of the appliance, operation of the warranty and could also affect your statutory rights.

Important

This appliance may contain some of the materials that are indicated. It is the Users/Installers responsibility to ensure that the necessary personal protective clothing is worn when handling, where applicable, the pertinent parts that contain any of the listed materials that could be interpreted as being injurious to health and safety, see below for information.

Firebricks, Fuel beds, Artificial Fuels - when handling use disposable gloves.

Fire Cement - when handling use disposable gloves.

Glues and Sealants - exercise caution - if these are still in liquid form use face mask and disposable gloves.

Glass Yarn, Mineral Wool, Insulation Pads, Ceramic Fibre, Kerosene Oil - may be harmful if inhaled, may be irritating to skin, eyes, nose and throat. When handling avoid inhaling and contact with skin or eyes. Use disposable gloves, face-masks and eye protection. After handling wash hands and other exposed parts. When disposing of the product, reduce dust with water spray, ensure that parts are securely wrapped.

WARNING - DO NOT STOCK FLAMMABLE MATERIALS IN OR NEAR THIS APPLIANCE. DO NOT SPRAY AEROSOLS IN THE VICINITY OF THIS APPLIANCE WHILE IT IS IN OPERATION. DO NOT MODIFY THIS APPLIANCE.

YOUR AGA COOKER

Is a heat storage cooker with an automatic gas control, which will keep the temperature of the cooker constant when not in use and return it to the constant temperature after use.

Your AGA is supplied with the following accessories:

- 1. Large roasting tin with grill rack.
- 1. Half-size roasting tin with grill rack.
- 2. Oven Grid Shelves.
- 1. Plain Shelf.
- 1. Toaster.
- 1. AGA Book.
- 1. Wire Brush

In addition there is a guarantee registration card which should be completed and returned to AGA.

A full description of cooking with your AGA is given in the AGA Book.

For the most effective operation of the cooker the following points should be carefully observed:

1. Close the insulating lids whenever the hotplates are not in use.
2. Clean the hotplates regularly with the wire brush.
3. Utensils with ground flat bases must be used to make perfect contact with the hotplates.
4. The hot water system must be thoroughly insulated (Model GCB & GEB).
5. Have the cooker serviced by your Authorised AGA Distributor.
6. Take care, when closing the oven doors, to lift them on to the catch.

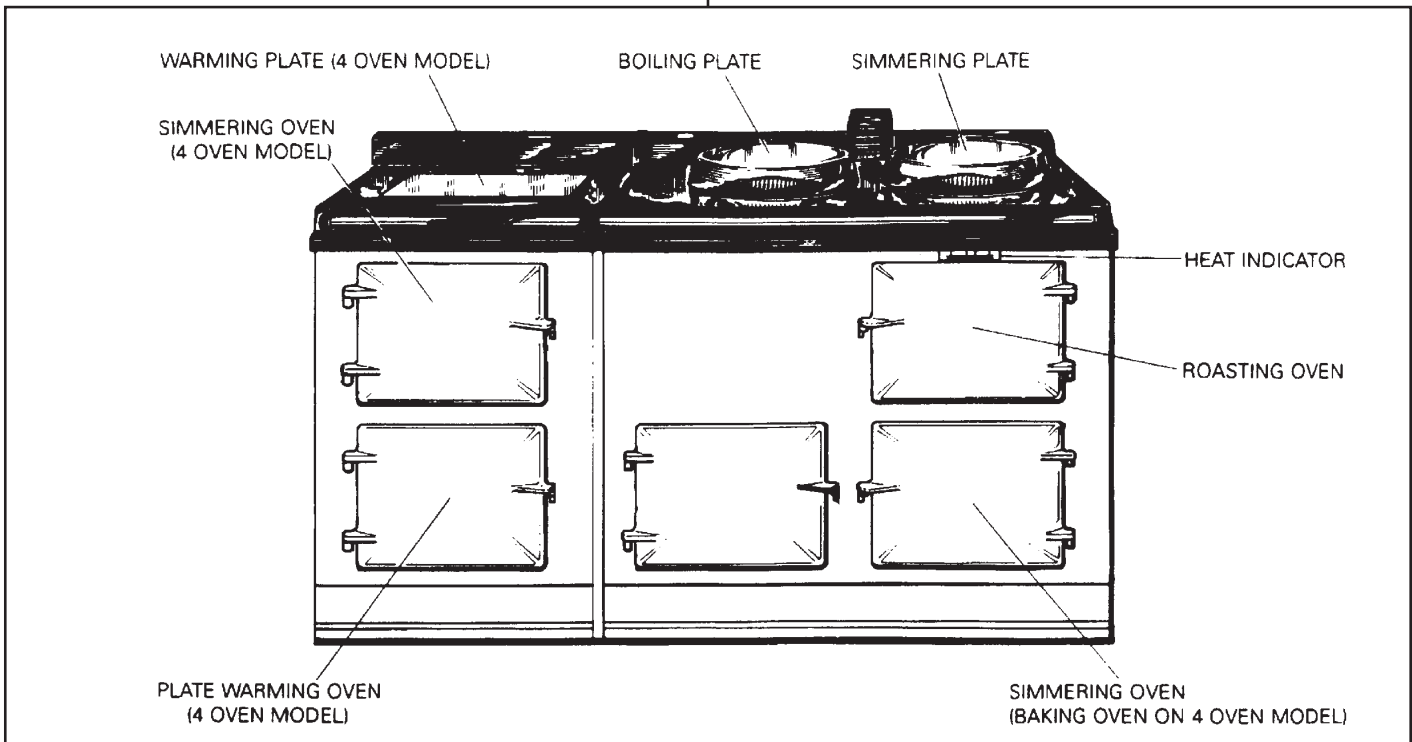

THE HEAT INDICATOR

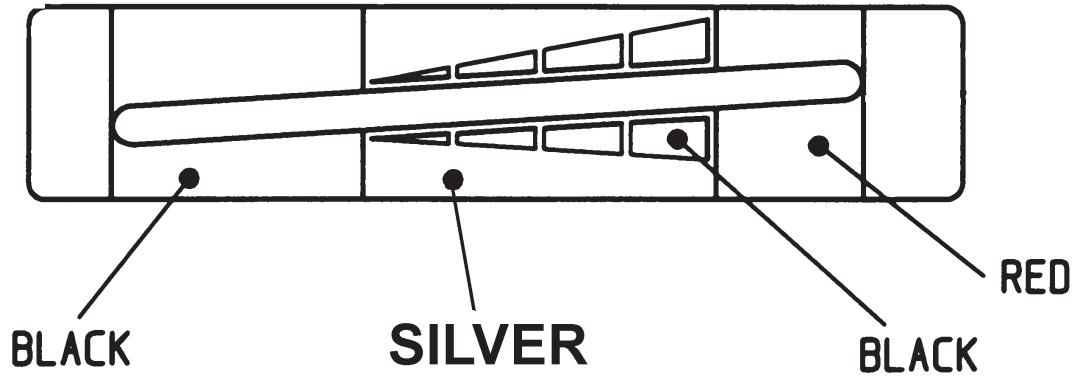

Fig. 1

DESN 515920

The heat indicator above the Roasting oven door is a guide to the stored heat within the AGA, and does not directly relate to the Roasting oven centre oven temperature.

It has 3 sections black, silver and red.

To obtain your preferred working temperature the control knob can be adjusted slightly. Once set it is not recommended to adjust on a regular basis. An AGA is designed to work at an optimum setting.

The optimum performance is usually achieved when the indicator is showing a mid-way position in the silver area.

Since the purpose of the heat indicator is to show that the AGA contains the full amount of stored heat it is best to refer to it first thing the morning or after a period of several hours during which no cooking has been done.

NOTE: IT DOES NOT INDICATE THE OVEN TEMPERATURE.

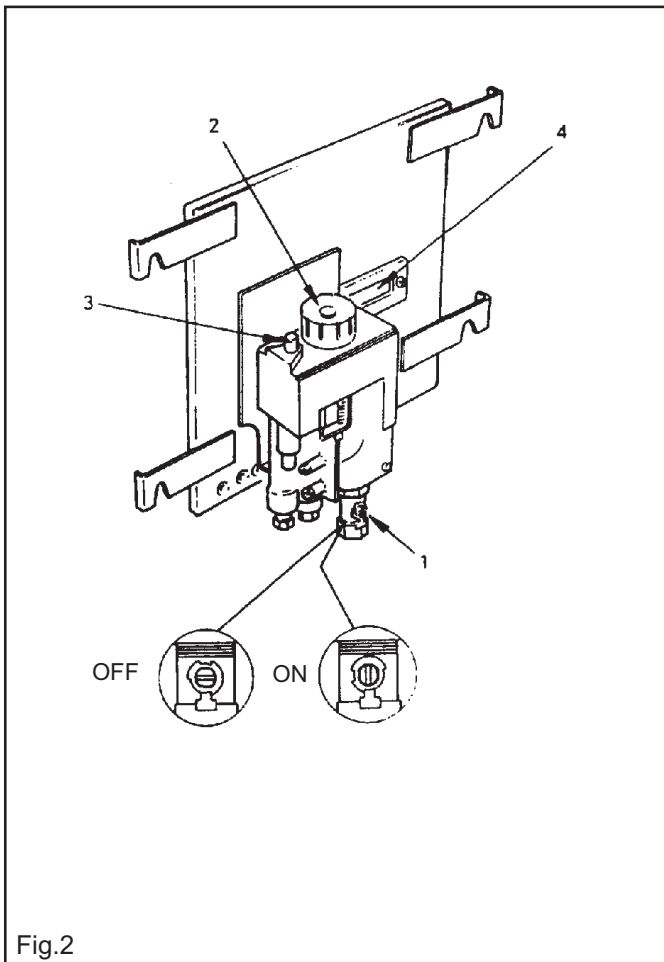

Fig.2

AUTOMATIC CONTROL

When the cooker is in use the gas control knob should be in the mid section of the green band, with the indicator on or about the centre of the silver section of heat indicator. It may be necessary to adjust the control knob slightly within the green band to achieve this.

TO EXTINGUISH THE BURNER

NOTE: REMEMBER TO NOTE THE SETTING OF THE GAS VALVE CONTROL KNOB 2 PRIOR TO EXTINGUISHING THE BURNER.

Turn the gas valve control knob clockwise to the off position (see fig. A).

Frost Precautions

In the event of the cooker being switched OFF for long periods during very cold weather, the advice of the Local Gas Region or Authorised Distributor should be obtained.

TO LIGHT THE BURNER

CAUTION: BEFORE LIGHTING: ENSURE THAT THE GAS VALVE CONTROL KNOB 2 IS SET IN THE OFF POSITION. (SEE FIG. A).

1. Turn on gas supply to cooker and open gas cock 1 at the base of the gas valve.
2. Turn the gas valve control knob 2 anti-clockwise to the position (⚙️) (see fig. B). Press down **firmly** and hold the knob in this position while depressing the piezo ignitor 3 several times until the pilot has lit. This can be observed through the viewing window. 4.
3. When the pilot has lit continue to hold the gas valve control knob down for approx. 30 seconds. If it goes out, wait three minutes and repeat the procedure holding for a little longer.
4. With the pilot flame established, release the control knob gradually and rotate anti-clockwise to its low fire position (see Fig. C), whereupon the main burner will light. Leave in the low fire position for at least 30 minutes.

NOTE: Any attempt to rotate the control knob before release may result in damage.

5. After 30 minutes rotate the control knob further anti-clockwise to the mid position in the green band for normal running. (see fig. D).

NOTE: AFTER SEVERAL HOURS THE HEAT INDICATOR SHOULD BE ON OR ABOUT THE CENTRE OF THE SILVER SECTION. IT MAY BE NECESSARY TO ADJUST THE CONTROL KNOB SLIGHTLY IN THE GREEN BAND TO ACHIEVE THIS.

When the cooker is lit from cold, moisture may form on the enamel which should be wiped off to prevent staining.

IF THE FLAME HAS EXTINGUISHED FOR WHATEVER REASON, WAIT THREE MINUTES (MINIMUM) BEFORE RE-LIGHTING.

SHOULD THE FLAME REPEATEDLY EXTINGUISH. CALL YOUR LOCAL AGA DEALER.

SERVICING

For continued efficient and safe operation of the appliance it is important that servicing is carried out at regular intervals as recommended by you AGA Distributor or Local Gas Region, once every 12 months. The cooker should be turned OFF by the User the night preceding the day of servicing so that the appliance will have cooled down by the following morning.

A HOT APPLIANCE CANNOT BE SERVICED.

OPERATING YOUR AGA

The following points are intended to help you during the period of change-over from your previous cooker to the AGA way of life. You will also find that the AGA Book provides a very useful introduction to the cooker.

After Your AGA has been Erected.

When first lit, your AGA will emit an odour for a short while. Do not worry, this is simply due to protective oil burning off the hotplates. If you can wipe the inside of the hotplate lids whilst the AGA is heating up it will avoid a film of this oil being deposited on the inside of the lids. Also, condensation may occur on the top plate and front plate whilst the AGA is heating up. This should be wiped away as soon as possible.

Beginning to Cook on Your AGA

The first "Golden Rule" of the AGA is to cook as much as possible in the ovens - without changing your menus. This not only conserves heat but also reduces cooking smells and condensation into the kitchen.

The Roasting Oven can also be used for grilling (at the top) and shallow frying (on the bottom).

Do keep the insulated lids down when the hotplates are not in use so that the heat stored in the cooker is conserved.

For optimum cooking performance, use the AGA utensils and the AGA cast iron cookware. They all have thick ground bases which give the best contact with the hotplates.

The AGA pans can be stacked in the Simmering Oven. This is especially useful for steaming vegetables and simmering sauces.

Store the Plain Shelf out of the AGA. Use it, cold in the Roasting Oven on a 2 oven AGA to deflect the heat from the top of the oven thus creating a more moderate oven temperature. It can also be used as a baking sheet.

The AGA Cake Baker can be used in the 2 oven AGA for cakes needing over 45 minutes cooking.

A guide to AGA cooking is given overleaf. Ask your Distributor for an invitation to an AGA demonstration.

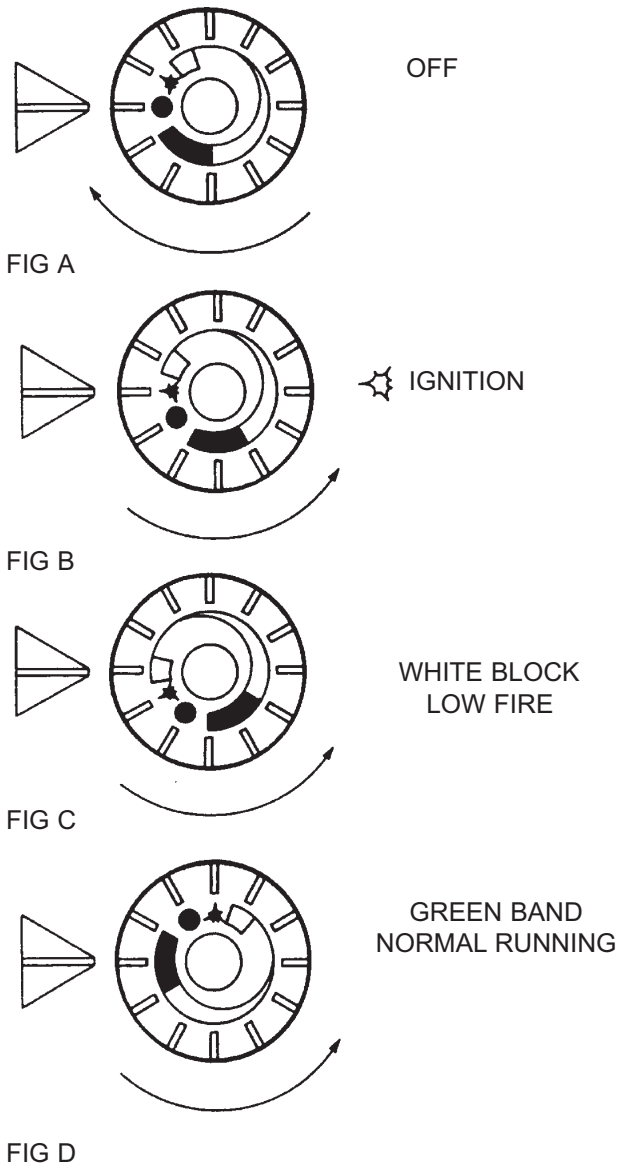

CLEANING AND CARING FOR YOUR AGA

REMEMBER: BE CAREFUL OF THE HOT APPLIANCE.

DO NOT USE ABRASIVE PADS OR OVEN CLEANER

DO NOT USE A STEAM CLEANER TO CLEAN THIS COOKER.

Top-plate and Front Plate

The easiest way to clean the AGA top-plate and front plate is to mop up spills as soon as they happen. Baked-on food is more difficult to clean but can usually be removed with proprietary vitreous enamel cleaners or mild cream cleaners using a cloth, or, if necessary, a nylon scouring pad. If milk, fruit juice, or anything containing acid, is spilt on the AGA, wipe it up immediately.

Also clean off any condensation streaks on the front plate around the oven doors or the vitreous enamel maybe permanently discoloured.

All that is usually needed to keep the vitreous enamelled surfaces of your AGA bright and clean is a daily rub over with a damp soapy cloth followed immediately with clean, a dry cloth to avoid streaks.

Remember the top-plate and the chrome lids will scratch if pans or utensils are dragged across them.

Insulating Lids and Oven doors

The linings of the insulating lids and oven doors may be cleaned with a cream cleanser or a soap impregnated pad.

Open the lids and lift off the oven doors to allow them to cool a little before cleaning. Do not, however, immerse the doors in water as they are packed with insulating material which will be damaged by excessive moisture. Refer also to the Cleaning Section in the AGA Book.

Ovens and Hotplates

The cast-iron ovens help to keep themselves clean; they merely need to be brushed out occasionally with a long handled stiff brush. The Simmering and Plate Warming Ovens on the 4 oven AGA may be cleaned with a damp soapy cloth.

The wire brush is provided for cleaning the hotplate and any burnt out spills in the cast iron ovens.

Roasting Tins

The roasting tins should be cleaned in hot, soapy water, soak if necessary, a nylon scouring pad can be used. **DO NOT** place in the dishwasher or use other caustic cleaners.

DO NOT USE ANY OVEN CLEANERS.

GUIDE TO AGA COOKERS

As the Aga Cooker is heated differently from an ordinary cooker, exact conversions are not possible. Look in the Aga Book for a similar recipe. Below is a quick guide to oven usage.

OVEN TEMPERATURE	TWO OVEN AGA	FOUR OVEN AGA
HIGH	ROASTING OVEN	ROASTING OVEN
GRILLING SCONES PASTRIES BREAD YORKSHIRE PUDDING ROASTS SHALLOW FRYING	Top - Grilling; 2nd runner - Scones, Small Pastries; 3rd runner - Bread Rolls, Yorkshire Pudding; 4th runner - Roasts, Poultry, Small Cakes in cases in the large meat tin. Grid shelf on oven floor - Loaves. Oven floor - Shallow frying. Quiche.	Top - Grilling; 2nd runner - Scones, Small Pastries; 3rd runner - Bread Rolls, Yorkshire Pudding; 4th Runner - Roasts, Poultry. Grid shelf on oven floor - Loaves Oven floor - Shallow frying, Quiche.
MODERATE	ROASTING/SIMMERING OVEN	BAKING OVEN
CAKES BISCUITS FISH SOUFFLÉS SHORTBREAD CHEESECAKES	Place grid shelf on floor of Roasting Oven. Protect food with the cold plain shelf slid on second or third runners. For cakes that require over 45 mins use the Cake Baker. Alternatively with fish, cheesecake, start off in Roasting Oven, finish in Simmering Oven.	Towards top - Whisked Sponges, Some Biscuits, Small Cakes Middle - Fish, Soufflés. Grid shelf on oven floor - Victoria Sandwiches, Shortbread and Cheesecake
LOW	SIMMERING OVEN	SIMMERING OVEN
CASSEROLES STOCK MILK PUDDINGS MERINGUES RICH FRUIT CAKE	For Casseroles, Stock, Milk Puddings, bring to heat elsewhere on the Aga then transfer to Simmering Oven. (One exception is Meringues). Rich Fruit Cakes can be cooked for a long time here	For Casseroles, Stock, Milk Puddings, bring to heat elsewhere on the Aga then transfer to Simmering Oven. (One exception is Meringues). Rich Fruit Cakes can be cooked for a long time here.

With AGA Rangemaster's policy of continuous product improvement, the Company reserves the right to change specifications and make modifications to the appliance described and illustrated at any time.



Manufactured by
AGA Rangemaster
Station Road
Ketley Telford
Shropshire TF1 5AQ
England

AGAAustralia.com.au
03 9521 4965
info@AGAAustralia.com.au